



United Technologies
turn to the experts 



AQUASNAP[®]

30RB/RQ

Air-Cooled Liquid Chiller Reversible Air-to-Water Heat Pump

Nominal cooling capacity: 159-761 kW (30RB)

Nominal cooling capacity: 163-430 kW (30RQ)

Nominal heating capacity: 189-510 kW (30RQ)

Features

- The Aquasnap Puron liquid chillers/air-to-water heat pumps are designed for commercial (air conditioning of villa, supermarket, office, hotel hospital etc.) or industrial (lowtemperature process chillers etc.) applications.

Benefits

- Environment sound refrigerant HFC-410A of zero ozone depletion potential.
- Standard unit with hydronic module (except for 30RB672/802) including all necessary hydronic components, easy and fast installation to save time, space and money.
- Low operating sound with no intrusive low-frequency noise, creates a better working/living environment.
- Electronic expansion valve (EXV) utilization, several compressors connected in parallel lead to more economical operating cost.
- Exceptional endurance tests ensure superior reliability to minimize chiller down-time.

Environmental sound

- Ozone-friendly HFC-410A refrigerant
 - Chlorine-free refrigerant of the HFC group with zero ozone depletion potential.
 - Very efficient - gives an increased energy efficiency ratio.
- Leak-tight refrigerant circuit.
 - Brazed refrigerant connections for increased leaktightness.
 - Reduction of leaks as no capillary tubes and flare connections are used.
 - Verification of pressure transducers and temperature sensors without transferring refrigerant charge.

Easy and fast installation

- Integrated hydronic module(except for 30RB672/802)
 - Centrifugal high or low-pressure water pump (as required).
 - Single or dual pump (as required) with operating time balancing and automatic changeover to the back-up pump if a fault develops.
 - Water filter protects the water pump against circulating debris.
 - High-capacity membrane expansion tank ensures pressurization of the water circuit.
 - Thermal insulation and anti-freeze protection down to -20°C by using an electric resistance heater.
- Simplified electrical connections
 - A single power supply point without neutral (except for 30RB672/802).
 - Main disconnect switch with high trip capacity.
 - Transformer for safe 24 V control circuit supply included.
- Fast commissioning
 - Systematic factory operation test before shipment.
 - Quick-test function for step-by-step verification of the instruments, electrical components and motors.

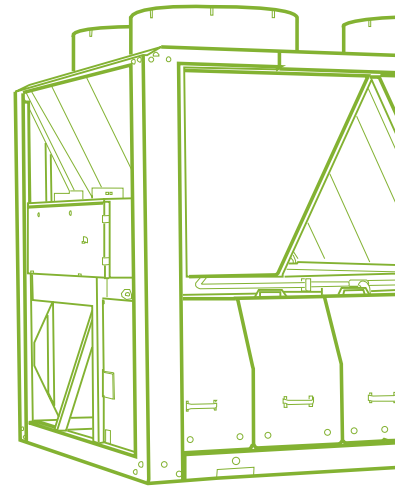

Quiet operation

Compressors

- Low-noise scroll compressors with low vibration level.
- The compressor assembly is installed on an independent chassis and supported by anti-vibration mountings.
- Dynamic suction and discharge piping support minimize vibration transmission (Carrier patent).
- Acoustic compressor enclosure reduces radiated noise emission (option).

Condenser section

- Condenser coils in V-shape with an open angle allows quieter air flow across the coil.
- Low-noise 4th generation Flying Bird fans (Carrier patent) enjoy quieter operation and never generate intrusive low-frequency noise.
- Rigid fan mounting preventing start-up noise (Carrier patent).



Economical operation

Increased energy efficiency at part load

- The refrigerant circuit includes several compressors connected in parallel. At part load, around 99% of the operating time, only the compressors that are absolutely necessary operate.
- The electronic expansion device (EXV) allows operation at a lower condensing pressure (EER and COP optimization).
- Dynamic superheat management for better utilization of the evaporator heat exchange surface.

Reduced maintenance costs

- Maintenance-free scroll compressors.
- Fast diagnosis of possible incidents and their history via the Pro-Dialog Plus control.
- HFC-410A refrigerant is easier to use than other refrigerant blends.

Absolute reliability

State-of-the-art concept

- Cooperation with specialist laboratories and use of limit simulation tools (finite element calculations) for the design of the critical components, e.g. motor supports, suction/discharge piping etc.

Exceptional endurance tests

- Corrosion resistance tests in salt mist in the laboratory.
- Accelerated ageing test on components that are submitted to continuous operation: compressor piping, fan supports.
- Transport simulation test in the laboratory on a vibrating table. The test is based on a military standard and equivalent to 4000 km by truck.

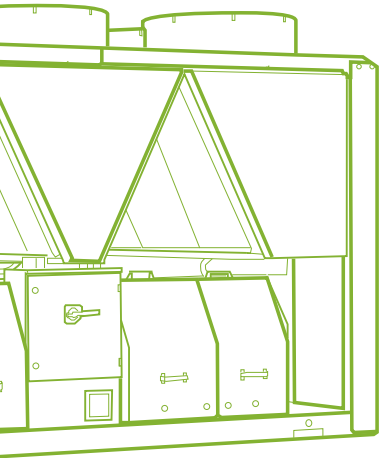

Pro-Dialog Plus Control

Pro-Dialog Plus combines advanced control logic with simple operation. The control system monitors all operation parameters all the time and precisely manages the operation of compressors, electronic expansion devices, fans and water pumps for optimized energy efficiency.

User-friendly interface

- ✔ User interface with synoptic diagram for intuitive display of the principal operating parameters: number of compressors operating, suction/discharge pressure, compressor operating hours, set-point, air temperature, entering/leaving water temperature.
- ✔ Ten menus for direct access to all machine commands, including fault history, allowing fast and complete chiller diagnostics.



Advanced control function

- ✔ Unit provides different control mode including LOCAL/REMOTE/CCN.
- ✔ Remote control function including: Unit ON/OFF, dual set point control, 2-level demand limit control, user safety interlock, water pump operation control, operation indication, circuit alarm and alert etc.
- ✔ Automatic reset of leaving water temperature based on return water temperature or outside air temperature to ensure optimized energy efficiency.
- ✔ Control algorithm prevents excessive compressor cycling and permits reduction of the water quantity in the hydronic circuit (Carrier patent).
- ✔ Automatic compressor unloading in case of abnormally high condensing pressure. If an abnormal incident occurs (e.g. fouled condenser coil, fan failure), Aquasnap continues to operate, but at reduced capacity.

Powerful diagnostics

- ✔ A quick test of all unit components and control points to verify the correct operation of every switch, circuit breaker, contactor etc. at the start of the chiller.
- ✔ Real-time monitor all the operation parameter, and alarm when necessary.
- ✔ Control system is facilitated with RS485 serial communication port for remote diagnosis or special diagnosis tools.

Sufficient safety measures

- ✔ Password protection in case of mishandling.
- ✔ Unit is protected against: Loss of refrigerant charge, reverse rotation, low chilled water temperature, current imbalance, compressor thermal overload, excessive air temperature, high pressure, electrical overload, loss of phase.

Group control

- ✔ Master/slave control of two chillers connected to automatically balance operating times, and also automatically conduct change-over in case of a unit fault.
- ✔ Communication with other Building Management System (BMS) by selecting BACnet/J-Bus/LonTalk gateway.

Technical Specifications

Performance data

30RQ		162	202	232	302	372	432	462
Nominal cooling capacity*	kW	163	195	221	275	331	389	430
Compressor power input	kW	48.8	65.8	70.8	98.1	115.8	139.1	153.6
EER	kW/kW	3.0	2.7	2.9	2.6	2.6	2.6	2.6
Nominal heating capacity*	kW	173	217	234	307	364	450	510
Compressor power input	kW	50.8	68.8	71.8	102.1	116.8	147.1	167.6
COP	kW/kW	3.0	2.9	3.0	2.8	2.9	2.8	2.8
Operating weight								
Unit with high-pressure single pump hydronic module	kg	2231	2425	2431	3245	3558	4268	4454
Unit without hydronic module	kg	2041	2235	2241	3045	3284	4028	4210
Refrigerant		HFC-410A						
Circuit A	kg	26.0	26.0	27.0	41.0	54.0	54.0	54.0
Circuit B	kg	26.0	26.0	27.0	27.0	32.0	47.0	53.0
Compressor		Hermetic scroll compressors						
Circuit A		1	1	2	3	4	4	4
Circuit B		2	2	2	2	2	3	4
Number of capacity stages		3	3	4	5	6	7	8
Minimum capacity	%	33	33	25	20	17	14	13
Control		Pro-Dialog Plus						
Air heat exchanger		Grooved copper tubes and aluminium fins						
Fans		Axial Flying Bird IV with rotating shroud						
Quantity		4	4	4	5	6	7	8
Total air flow	l/s	18056	18056	18056	22569	27083	31597	36111
Speed	rpm	950	950	950	950	950	950	950
Water heat exchanger		Direct expansion shell-and-tube						
Water volume	l	110	110	110	110	113	113	113
Nominal water flow rate, cooling mode	l/s	7.9	9.4	10.3	13.6	16.4	19.3	21.7
Nominal water flow rate, heating mode	l/s	8.2	10.5	10.9	15.2	18.0	22.3	25.7
Unit internal water pressure drop, cooling mode	kPa	22	23	26	39	31	41	51
Unit internal water pressure drop, heating mode	kPa	24	27	28	45	37	54	71
Max. water-side operating pressure without hydronic module	kPa	1000	1000	1000	1000	1000	1000	1000
Hydronic module		Pump, victaulic screen gilter, safety valve, expansion tank, purge valves etc.						
Water pump		Centrifugal pump						
Water head external to chiller								
Single pump at nominal water flow rate, cooling mode	kPa	185	173	211	183	225	198	245
Single pump at nominal water flow rate, heating mode	kPa	179	162	203	164	205	152	178
Expansion tank	l	50	50	50	80	80	80	80
Max. water-side operating pressure with hydronic module	kPa	400	400	400	400	400	400	400
Water connection		Victaulic						
Diameter (with hydronic module)		DN100	DN100	DN100	DN100	DN125	DN125	DN125
Diameter (without hydronic module)		DN100	DN100	DN100	DN100	DN150	DN150	DN150
Electrical data		400V-3Ph-50Hz						
Main power supply		Via internal transformer						
Control power supply								
Nominal unit operating current draw	A	113	137	143	195	233	282	322
Maximum operating current draw	A	143	176	183	251	299	364	414
Maximum start-up current	A	316	383	356	459	507	573	623
Fan and control power	kW	6.2	6.2	6.2	7.9	9.2	10.9	12.4
Pump power input (high pressure single pump)	kW	4.2	4.7	4.7	6.4	8.5	8.5	12.2

* Nominal cooling mode - evaporator entering/leaving water temperature 12/7 C , outside air temperature 35 C ;
 Nominal heating mode - water heat exchange entering/leaving water temperature 40/45 C , outside air temperature 7 C ;
 Water heat exchanger fouling factor 0.018m²K/kW.

Operating Range, 30RQ 162 - 462

Cooling mode

Water heat exchanger (evaporator)		
	Minimum	Maximum
Entering water temperature at start-up	6.8 C	30 C
Leaving water temperature during operation	5 C	15 C
Entering water temperature at shut-down	-	60 C
Air heat exchanger (condenser)		
	Minimum	Maximum
Outdoor air temperature	0 C	46 C

Heating mode

Water heat exchanger (condenser)		
	Minimum	Maximum
Entering water temperature at start-up	3.4 C	45 C
Leaving water temperature during operation	20 C	50 C
Entering water temperature at shut-down	3 C	60 C
Air heat exchanger (evaporator)		
	Minimum	Maximum
Outdoor air temperature	-10 C	35 C

Operating range – cooling mode

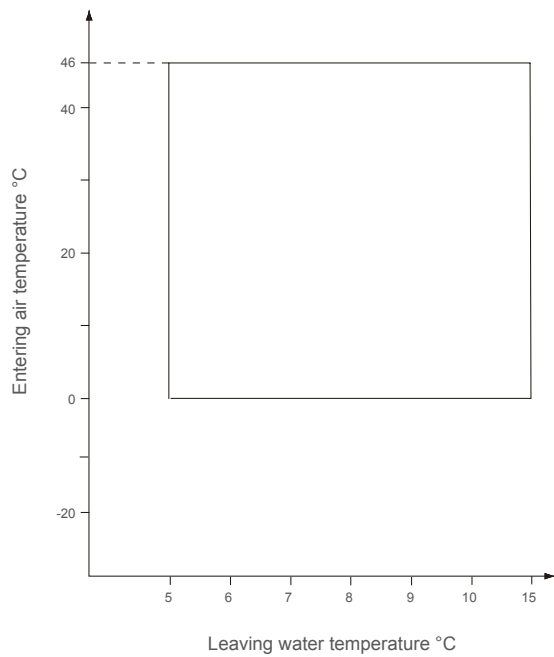

Operating range – heating mode

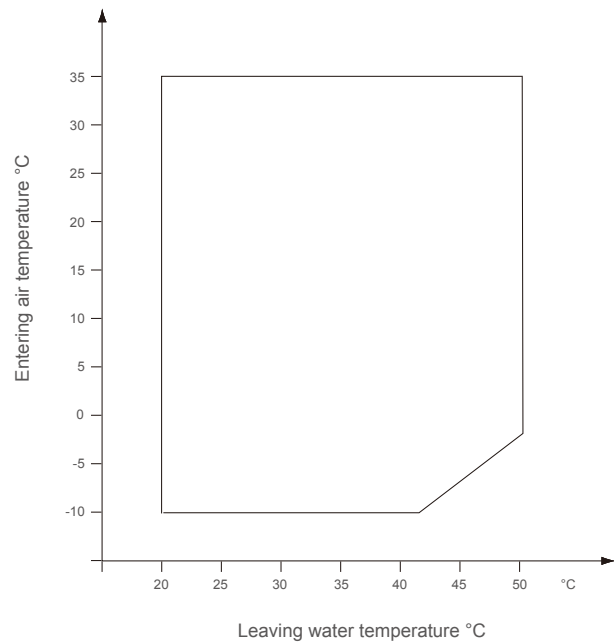

Note: Water heat exchanger and air heat exchanger $\Delta t = 5 \text{ K}$

Operating range, standard unit

Options & accessories

Options	No.	Description	Advantages	Use
Blygold PoluAL	002B	Coil with factory-applied Blygold PoluAL treatment	Improved corrosion resistance, recommended for heavy marine and industrial environments	30RB162/192/672/802
Gold Fin	003A	Fin made of pre-treated aluminium (polyurethane and epoxy)	Improved corrosion resistance, recommended for light marine environments	30RB162/192/672/802
Low brine	006	Leaving water temperature down to -10°C	For low temperature applications such as ice storage, cold stores or process cooling etc.	30RB162/192
High external static pressure	012	1130RPM to provide 150Pa static pressure for indoor unit installation with ducts	Available for ducted condenser air discharge, optimized condensing temperature control	30RB162/192/672/802
Low noise	015	Compressor sound enclosure	Low operating noise	30RB162/192/672/802 30RQ162~462
Super low noise	015LS	Compressor sound enclosure and low-speed fan	Super low operating noise	30RB162/192/672/802
MCHX bare coil	018	Micro-channel heat exchanger	30% reduction of refrigerant charge amount and convenient to clean by a high pressure washer	30RB162/192/672/802
Protection grilles	023	Metallic grilles on the four unit faces	Better chiller protection and aesthetics	30RB162/192/672/802 30RQ162~462
Winter operation	028	Fan speed control by frequency inverter	Stable operation between 0°C and -20°C outdoor air temperature	30RB162/192/672/802
Winter operation B	028B	Two-speed fan motor for each circuit	Stable operation between 0°C and -10°C outdoor air temperature	30RB162/192/672/802
Partial heat recovery	049	Partial heat recovery by desuperheating the compressor discharge gas	Free high-temperature hot-water production simultaneously with chilled water production	30RB162/192/672/802 30RQ162~462
Lead/lag control	058	Unit equipped with an additional field-installed leaving water temperature sensor, allowing master/slave operation of two heat pumps connected in parallel	Optimized operation of two units connected in parallel with operating time equalization	30RB162/192/672/802 30RQ162-462
Suction valve	092	Shut-off valves on the compressor suction piping (discharge valve as standard)	Simplified maintenance	30RB162/192/672/802 30RQ162-462
High pressure dual pump hydronic module	116C	Provide integrated hydronic module with high pressure dual pump	Easy and fast installation, operating safety	30RB162/192 30RQ162~462

Options & accessories

Options	No.	Description	Advantages	Use
Unit without hydronic module	116D	Flexible for customer to purchase and install the water components by themselves	-	30RB162/192/672/802 30RQ162~462
Low pressure single pump hydronic module	116F	Provide integrated hydronic module with low pressure single pump	Easy and fast installation	30RB162/192 30RQ162~462
Low pressure dual pump hydronic module	116G	Provide integrated hydronic module with low pressure dual pump	Easy and fast installation, operating safety	30RB162/192 30RQ162~462
Super high pressure single pump hydronic module	116H	Provide integrated hydronic module with super high pressure single pump	Easy and fast installation	30RB162/192 30RQ162~462
Super high pressure dual pump hydronic module	116I	Provide integrated hydronic module with super high pressure dual pump	Easy and fast installation, operating safety	30RB162/192 30RQ162~462
J-Bus gateway	148B	Two-directional communication board with J-Bus protocol	Easy connection by communication bus to building management system	30RB162~802 30RQ162~462
BacNet gateway	148C	Two-directional communication board with BacNet protocol	Easy connection by communication bus to building management system	30RB162/192/672/802 30RQ162~462
LonTalk gateway	148D	Two-directional communication board with LonTalk protocol	Easy connection by communication bus to building management system	30RB162/192/672/802 30RQ162~462
Energy Management Module (EMM)	156	See control manual	-	30RB162/192/672/802 30RQ162~462
Cu/Al condenser coils	254	Coils made of copper tube with aluminium fin	-	30RB162/192/672/802
Super Enviro shield MCHX coils	263	E-coated MCHX coils	Improved corrosion resistance, recommended for heavy marine and industrial environments	30RB162/192/672/802

Dimensions/Clearances

30RQ162~232

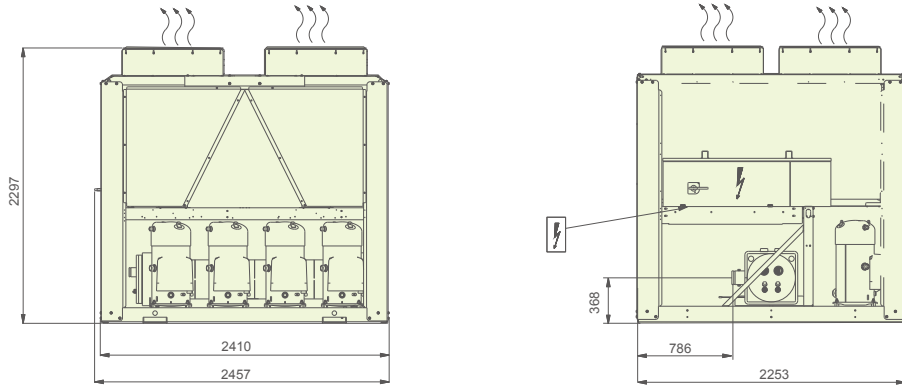

Standard unit with high pressure single pump hydronic module*

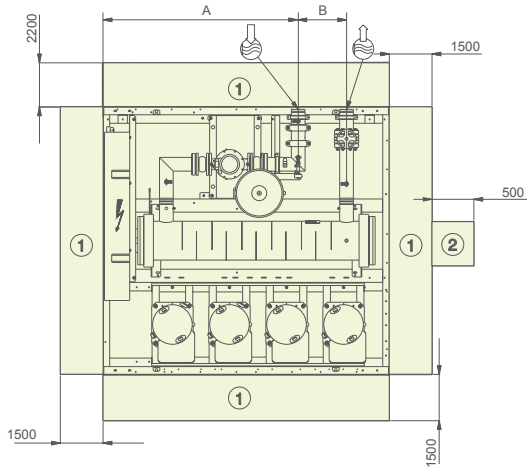

30RB	30RQ	A	B	C	D
162/192		1643	403	543	1503
	162~232	1643	393	543	1493

Unit without hydronic module

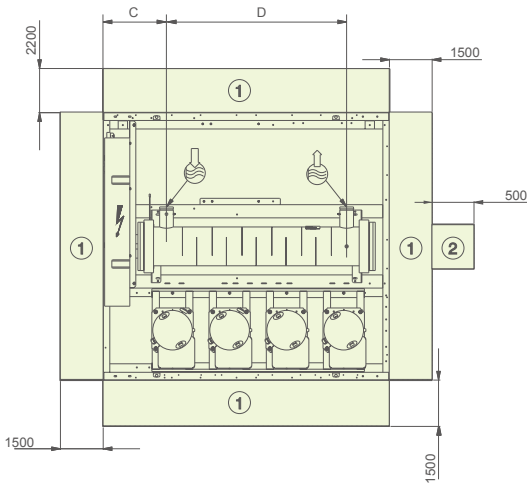

Legend:

All dimensions are given in mm.

- ① Required clearances for maintenance and air flow
- ② Recommended space for evaporator tube removal
- Water inlet
- Water outlet
- Power supply connection
- Air outlet - do not obstruct

*Please contact local Carrier operation for other integrated hydronic module options

Multiple Chiller Installation

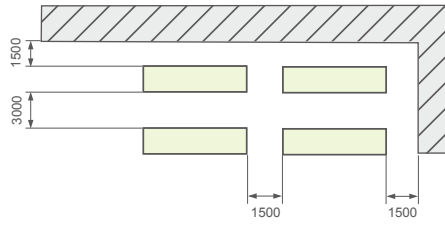
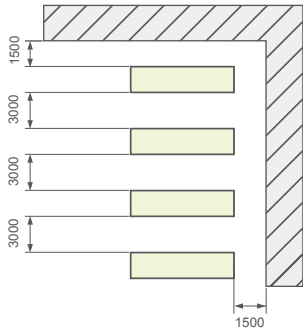

Note: If the height of wall exceeds 2m, please contact local Carrier Sales & Service Corporation.

Weight Distribution

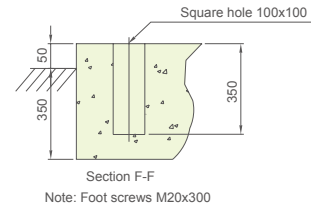
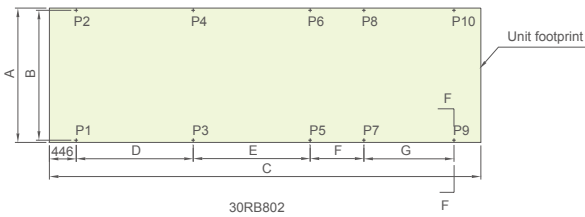
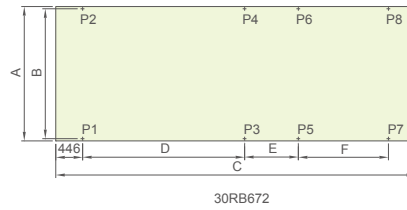
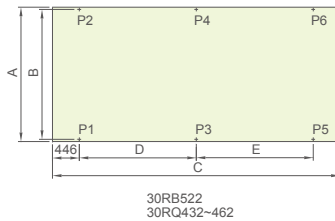
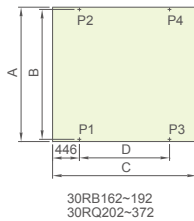

Models	Dimensions (mm)							Weight distribution (kg)										Operating weight
	A	B	C	D	E	F	G	P1	P2	P3	P4	P5	P6	P7	P8	P9	P10	
30RB162PT254	2231	2157	2388	1496	-	-	-	508	478	591	555	-	-	-	-	-	-	2130
30RB192PT254	2231	2157	2388	1496	-	-	-	554	496	671	601	-	-	-	-	-	-	2320
30RB672PT116D/254	2231	2157	5970	2690	892	1496	-	929	742	832	639	832	638	568	461	-	-	5640
30RB802PT116D/254	2231	2157	7164	1942	1942	892	1496	527	402	1180	962	679	604	679	679	552	246	6510
30RQ162	2231	2157	2388	1496	-	-	-	532	500	619	582	-	-	-	-	-	-	2231
30RQ202	2231	2157	2388	1496	-	-	-	579	518	702	628	-	-	-	-	-	-	2425
30RQ232	2231	2157	2388	1496	-	-	-	530	656	556	691	-	-	-	-	-	-	2431
30RQ302	2231	2157	3582	2690	-	-	-	901	755	865	724	-	-	-	-	-	-	3245
30RQ372	2231	2157	3582	2690	-	-	-	952	759	1029	818	-	-	-	-	-	-	3558
30RQ432	2231	2157	4776	1942	1942	-	-	648	526	1059	811	683	541	-	-	-	-	4268
30RQ462	2231	2157	4776	1942	1942	-	-	676	549	1106	847	713	565	-	-	-	-	4454

Hydronic Connections

Standard unit with integrated high pressure single pump hydronic module (except for 30RB672/802)

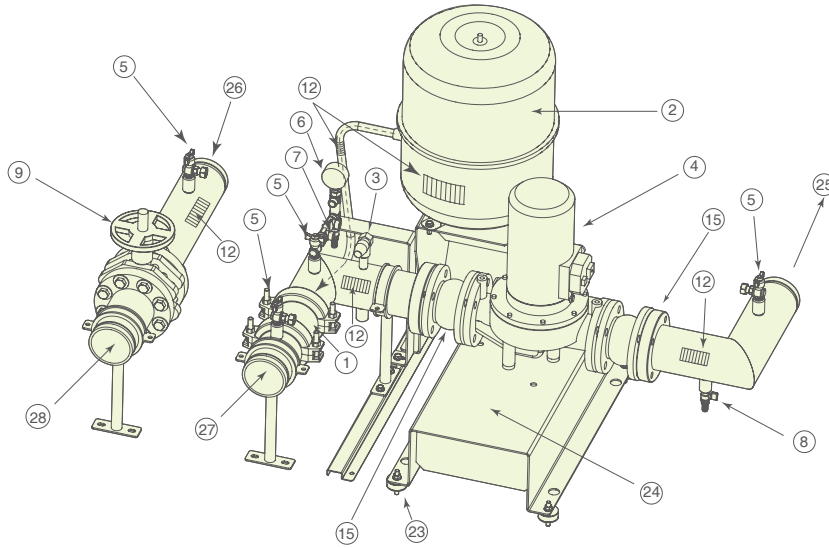
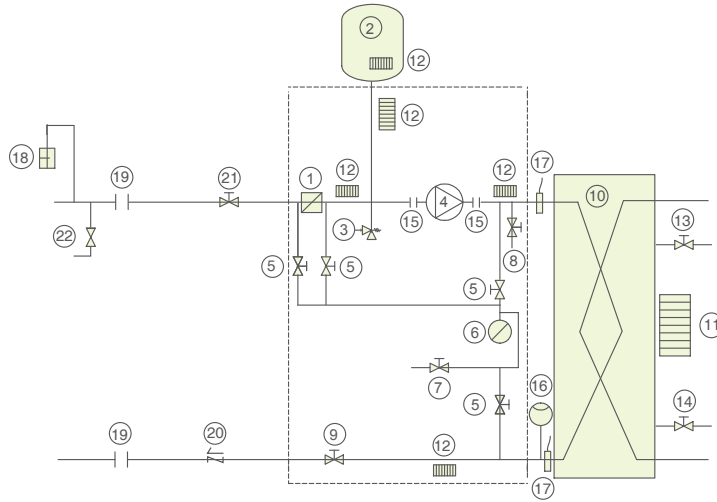

Legend:

Components of the unit and hydronic module

- 1. Victaulic screen filter
- 2. Expansion tank
- 3. Safety valve
- 4. Water pump
- 5. Shut-off valve
- 6. Pressure gauge
- 7. Air vent
- 8. Drain valve
- 9. Water flow control valve
- 10. Shell-and-tube heat exchanger
- 11. Evaporator heater
- 12. Hydronic module heater
- 13. Air vent (evaporator)
- 14. Water purge (evaporator)
- 15. Flexible connections
- 16. Electronic flow switch
- 17. Water temperature sensor

Installation components

- 18. Air vent
- 19. Flexible connections
- 20. Check valve
- 21. Shut-off valve
- 22. Water charge valve
- 23. Anti-vibration pad
- 24. Water pump support

Water flow directions

- 25. Evaporator water inlet
- 26. Evaporator water outlet
- 27. Hydronic module water inlet
- 28. Hydronic module water outlet

Heat Exchanger Water Pressure Drop

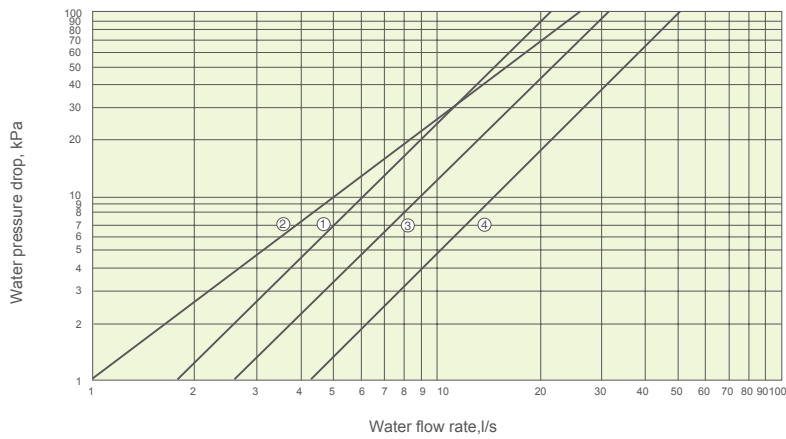

- ① 30RB162~192
- ② 30RQ162~302
- ③ 30RQ372~462
- ④ 30RB672~802

Available Static Pressure

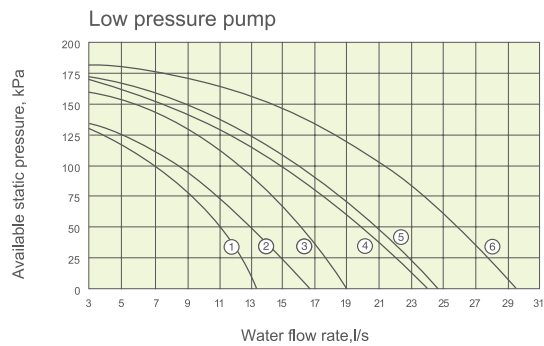

- ① 30RB162~192/30RQ162~202
- ② 30RQ232
- ③ 30RQ302
- ④ 30RQ372
- ⑤ 30RQ432
- ⑥ 30RQ462

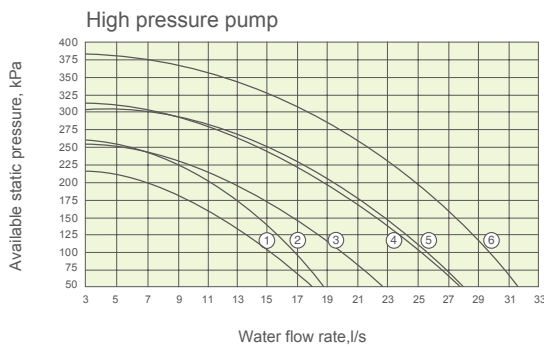

- ① 30RB162~192/30RQ162~202
- ② 30RQ232
- ③ 30RQ302
- ④ 30RQ372
- ⑤ 30RQ432
- ⑥ 30RQ462

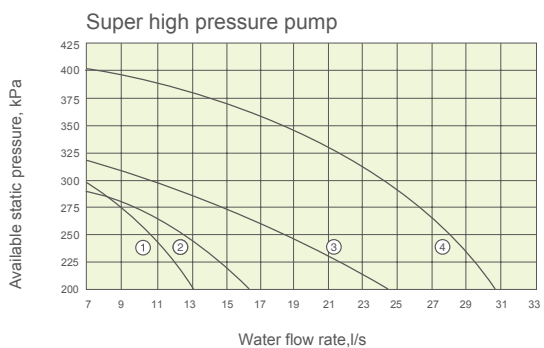

- ① 30RB162~192/30RQ162~232
- ② 30RQ302
- ③ 30RQ372/30RQ432
- ④ 30RQ462

Minimum Water Loop Volume

For better control of leaving water temperature, the water loop minimum capacity is given by the formula:

$$\text{Capacity} = \text{CAP (kW)} \times \text{N Liters}$$

Application		N
Normal air conditioning	30RB162/192/672/802 / 30RQ162~462	3.5
Process cooling	30RB162/192/672/802 / 30RQ162~462	6.5

Where Cap is the nominal system cooling capacity (kW) at the nominal operating conditions of the installation. This volume is necessary for stable operation and accurate temperature control.

It is often necessary to add a buffer water tank to the circuit in order to achieve the required volume. The tank must be internally baffled in order to ensure proper mixing of the liquid (water or brine). Refer to the examples below.

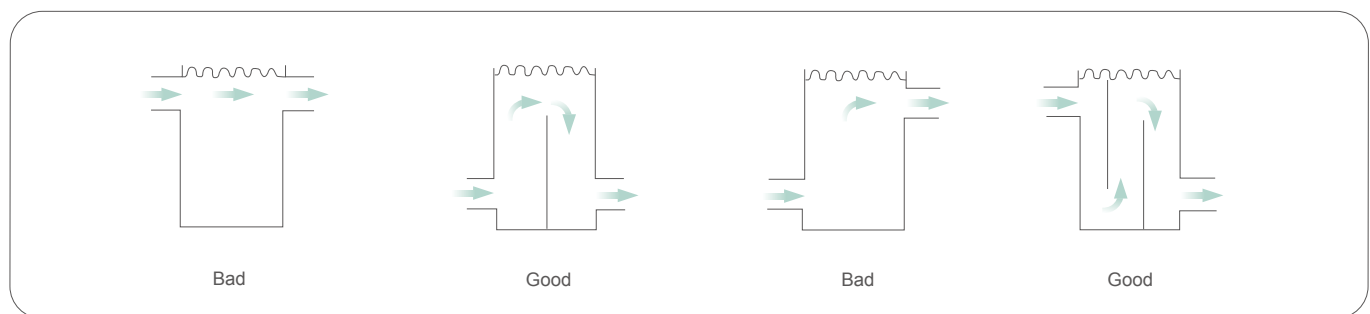

Field Control Wiring

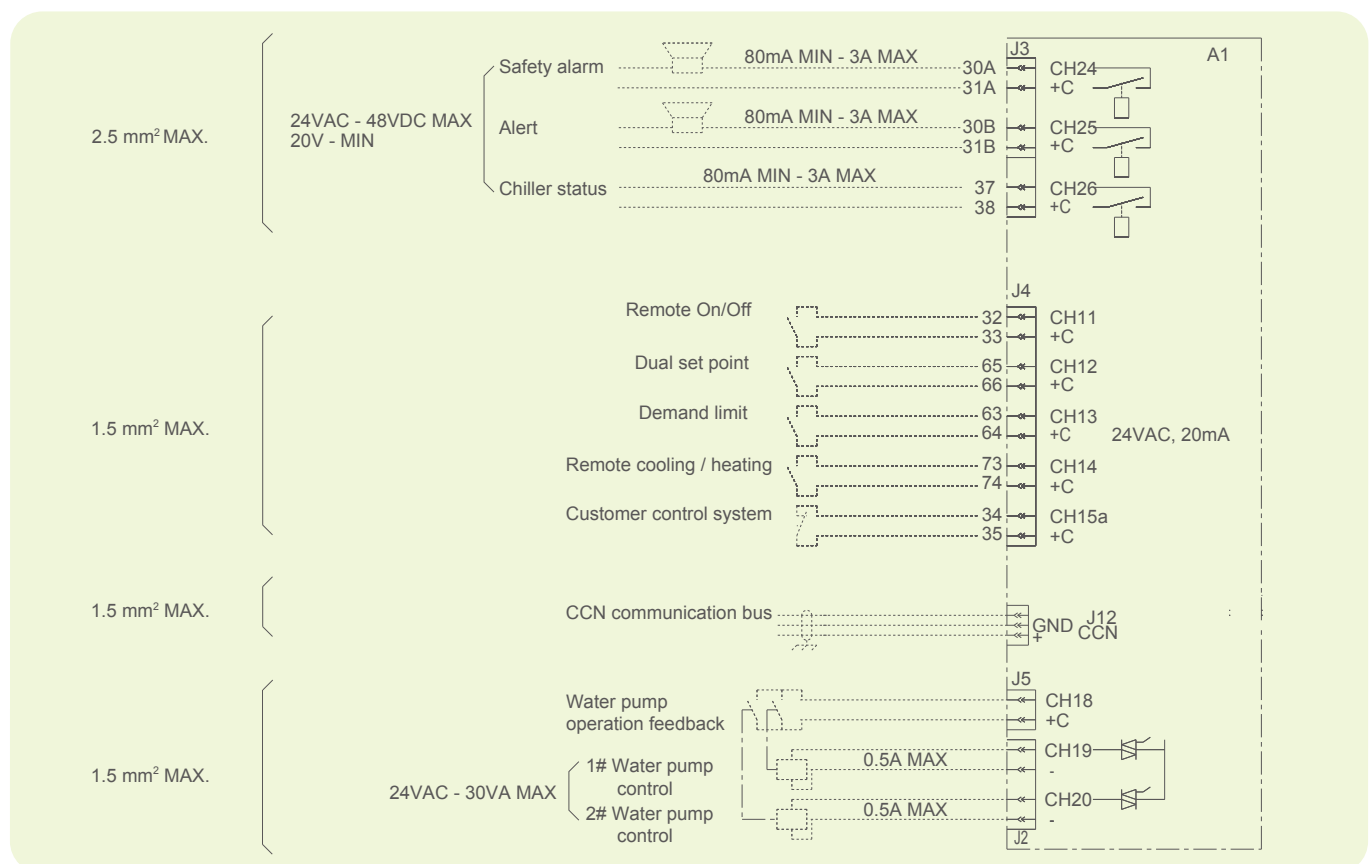



Carrier improves the world around us; Carrier improves people's lives; our products and services improve building performance; our culture of improvement will not allow us to rest when it comes to the environment.



www.carrier.com

The Manufacturer reserves the right to change any product specifications without prior notices
© All Rights Reserved Carrier

Version:	CAT_30RB/RQ_E-1409_03
Supersede:	CAT_30RB/RQ_E-1210_02
Effective Date:	Sep, 2014